



PRODUCT SUPPORT MANUAL YACHT BEAM 1M

Searchlight Remote Control System



TABLE OF CONTENTS

SECTION 1 - PRODUCT DESCRIPTION	3
SECTION 2 - SEARCHLIGHT MOUNTING	4
SECTION 3 - REMOTE CONTROL SYSTEM	5
SECTION 4 - POINT PAD™	5
SECTION 5 - MASTER CONTROLLER	6
SECTION 6 - POINT PAD™ OPERATION	8
APPENDIX A - SPECIFICATIONS	10
APPENDIX B - KIT COMPONENTS	10
APPENDIX C - WIRING DIAGRAM	11
APPENDIX D - WARRANTY, NOTICES	12



PLEASE READ ALL WARNINGS, CAUTIONS AND NOTES CAREFULLY.



CAUTION: Before proceeding to install, test or use your new Yacht Beam product, please read this Product Support Manual in its entirety.

SECTION 1 - PRODUCT DESCRIPTION

Introduction

The Yacht Beam 1M was specially designed for mariners who require a high intensity remote controlled searchlight that can stand up to the tough marine environment.

The sleek design and modern construction of the searchlight body makes it attractive for recreational and commercial vessels. The searchlight is totally enclosed and is made of rugged aluminum alloy. It is gasketed and finished to be resistant to the weather.

The Yacht Beam 1M searchlight contains a narrow beam searchlight that produces 1,000,000 peak candle power by combining twin 35W metal halide HD lamps providing over 500K candela (CD) each and 1 million effective CD when combined.

All functions of the searchlight can be electrically operated by remote control from the pilot area or the vessel using the Point Pad™, Master Controller and interconnect cable supplied with the Yacht Beam 1M. Searchlights equipped with the Master Controller have a self-park feature and Yacht Beam's unique XRCiZ™ feature. The XRCiZ™ feature routinely operates all moving parts in the searchlight to keep the motors and drive mechanisms freely running.

Unpacking the Yacht Beam 1M

Your new Yacht Beam 1M Remote Control Searchlight System comes with the following components:

1. Yacht Beam 1M searchlight
2. Coaxial Cable Kit
3. Product Support Manual, Warranty Card, Mounting Templates, etc.
4. Point Pad™ with Installation Kit
5. Master Controller with Installation Kit



Figure 1 - Yacht Beam 1M

SECTION 2 - SEARCHLIGHT MOUNTING

Make sure the area is clean and dry. The searchlight can be mounted where desired, using appropriate length 5/16" diameter stainless steel fasteners. One set is provided in the mounting kit and four (4) nylon shoulder washers. The nylon washers prevent a galvanic reaction between the mounting hardware and the base of the searchlight. Be sure these washers have been inserted in the base mounting holes and that the mounting base gasket is securely in place before bolting down. Apply silicone grease to the bottom of the gasket to help in waterproofing the unit. When mounting, be sure the searchlight is able to rotate 360° without hitting any obstructions. For the drilling hole pattern, refer to the searchlight Mounting Template.



CAUTION: Do not mount the searchlight upside down. Moisture cannot drain from the inverted light head assembly.

Self Park Feature

The Yacht Beam 1M has a Self-Park feature. The Self Park function will automatically return the light to a specific position when turned off. When mounting the light, determine in advance the direction that the light should face when it is turned off. Align the red marker on the base 180° opposite of the final facing direction.

To activate the Self-Park feature, press the "Speed" button on the Point Pad™ for more than five (5) seconds.

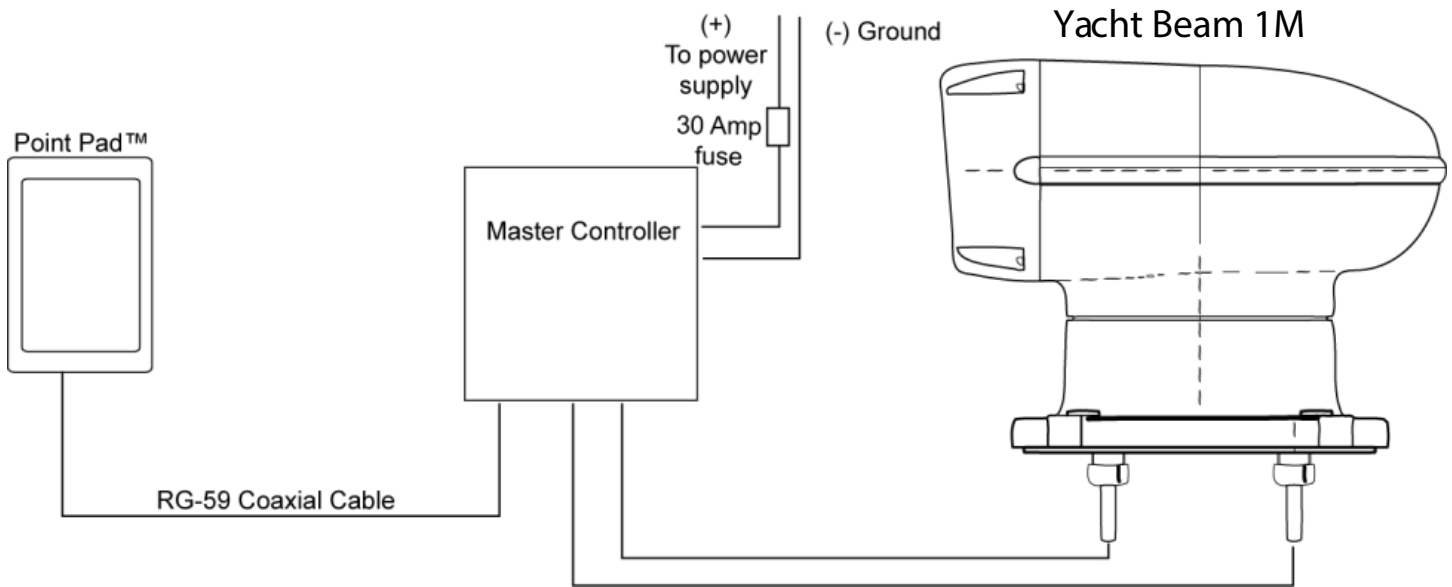

**Figure 2 - Master Controller unit (mounted upright)
Single Point Pad connection configuration**

SECTION 3 - REMOTE CONTROL SYSTEM

The Remote Control System consists of the Master Controller and the Point Pad™. This system is compatible with 12 VDC through 24 VDC systems without modification.

SECTION 4 - POINT PAD™

Case options

The Point Pad™ is supplied as a surface mount unit (see Figure 3). A flush mount option is provided. To switch mounting options, unscrew the six (6) screws on the unit's back plate and remove the front cover. Fit the Point Pad™ with the flush mount cover, replace the back plate and screw the unit back together.

Mounting

Both the surface mount and the flush mount options require access to the backside of the mounting location. Verify that there are not any obstructions behind the area where the switch is to be located, e.g., bulkheads, wires, plumbing or hardware. Check that the coax cable from the Master Controller can be routed to this location. Generally, the Point Pad™ should be mounted in a protected area.

Surface Mount

Install the surface mount Point Pad™ by drilling three (3) holes in the dashboard location using the Point Pad™ Surface Mount Template supplied in the Mounting Templates. Mount the Point Pad to the dashboard using the gasket, washers and nuts supplied. Apply a sealant around the bolt holes to protect from moisture intrusion.



**Surface Mount
POINTPAD™**

Flush Mount

When the flush mount is selected, cut a rectangular hole in the dashboard location using the Point Pad™ Flush Mount Template supplied in the Mounting Templates. Use the gasket, washers, nuts and the two U-Clamps provided to secure the Point Pad™. Apply a sealant around the cut out to protect from moisture intrusion.



**Flush Mount
POINTPAD™**

Connecting to the Master Controller

The Point Pad™ communicates with the Master Controller via standard television type RG-59 coaxial cable. The connectors are standard "F" type television connectors. The connector on the back of the Point Pad™ is located in the center of the panel for ease of installation. After the coax cable has been routed and the "F" connector is attached to the coax cable, screw the "F" connectors to the Master Controller and the Point Pad™.

Additional Point Pads™ (up to three) may be used with one (1) Master Controller. A standard "T" connector or RG-59 television type splitter is used for each additional Point Pad™. Limit the total length of all coax cable used to 300 feet.

SECTION 5 - MASTER CONTROLLER

Mounting

The Master Controller can be mounted in any position near the searchlight that is protected from the weather. Check in advance that the coax cable from the Point Pad and the wiring harness from the searchlight can be routed to this location. Mount the Master Controller with the wires and coax facing down. Use an appropriate fastener for your mounting location. Use a sealant in fastener holes to prevent moisture intrusion.

General wiring scheme



WARNING: The Yacht Beam 1M has a unique wiring scheme. Special attention must be paid to the following chart.

The Master Controller is supplied with an in-line fuse-holder on the Orange power lead. Use only 30 amp fuses in this fuse-holder. See chart below for the Master Controller wiring diagram.



WARNING: Failure to follow this arrangement may damage components.

MASTER CONTROLLER WIRE	SEARCHLIGHT CABLE WIRE	WIRE GAUGE (AWG)	POWER SOURCE LEAD	FUNCTION
Orange		16	+12 VDC OR +24 VDC**	Master Controller Power
Blue		16	Ground	Master Controller Ground
Yellow	Yellow	16		Position Sensor Signal
Green	Green	16		Position Sensor Common
Red	Red	16		Up
White	White	16		Down
Black	Black	16		Right
Brown	Brown	16		Left
White	White	12		Lamp Power
Black	Black	12		Lamp Ground

Table 1



WARNING: This wire MUST be fused with a 30 amp fuse in the Master Controller's in-line fuse-holder.

Wiring to the searchlight

The Yacht Beam 1M searchlight is supplied with a 15-foot integral wire harness. If you must lengthen the wire harness, use heavy duty wire to minimize the voltage drop. This is especially important for the WHITE 12 AWG lamp power, BLACK 12 AWG lamp ground, ORANGE power wire and BLUE ground wires.

Following the wiring scheme above and Appendix C. use the supplied butt connectors to connect the Master Controller to the searchlight.

Wiring the Point Pad™

The RG-59 coax cable is supplied without the "F" connectors attached for ease of routing. After the Coax cable has been routed, strip the insulation and crimp the "F" connectors in place. Screw the "F" connectors to the Master Controller and the Point Pad™.

Wiring to the power supply

The power source must be a fused 12 VDC, 30-amp supply or a 24 VDC, 15-amp supply. Following the wiring scheme in Table 1, use the supplied butt connectors to connect the Master Controller to the power source. Refer to Table 2 for proper wire size for connection of the input powerlines.



NOTE: As per the wiring scheme, the ORANGE wire is connected to the positive terminal and the BLUE wire is connected to the negative terminal of the power source.



CAUTION: HID light systems, when first turned on, have a high inrush current requirement of 25 amps. If you activate the light and the lamps flicker on and off repeatedly, check the voltage being supplied. This condition can be experienced with voltage input of less than 11.5V.

Functions of the Master Controller

The Master Controller is designed to perform up to six different duties on searchlights, winches and other electrical devices. The Master Controller provides optimum voltage to ensure brightest performance and long lamp life, regardless of boat system voltage fluctuations. The Master Controller is compatible with devices requiring 12 VDC through 24 VDC operation.

The Master Controller has a searchlight motor time-out feature. If a Point Pad™ rotation switch (right or left) is continually engaged for more than 50 seconds, the Master Controller will interrupt the operation until the Point Pad switch is disengaged. This feature will save the searchlight motor from burnout due to accidental activation. The elevation motor has similar features which will timeout in approximately 20 seconds.

XRCiZ™ feature

The Master Controller has the unique XRCiZ™ feature. The XRCiZ™ feature routinely operates all moving parts of the searchlight to keep the motors and drive mechanism freely running. Once activated, and every 30 days thereafter, the XRCiZ™ feature wakes up and operates the searchlight. The searchlight will rotate 360° in both directions and the parabolic reflectors will move to the full up and down positions. This feature keeps the searchlight in peak working order when not in service for long periods of time.

To activate the XRCiZ™ feature, press and hold the Point Pad™ ON/OFF button for greater than 5 seconds. The green LED on the Point Pad™ indicates that the XRCiZ™ feature is enabled.

While the XRCiZ™ feature is operating the searchlight, pressing any Point Pad™ button will stop the XRCiZ™ command.

To deactivate the XRCiZ™ feature, press and hold the Point Pad ON/OFF button for greater than 5 seconds. The red LED on the Point Pad™ indicates that the XRCiZ™ feature is disabled.

NOTE: The Searchlight should not be covered while the XRCiZ™ feature is enabled.

Self- Park feature

The Master Controller has a Self- Park feature. When the Self-Park feature is activated, it will automatically return the searchlight to the forward (or aft, if mounted as such) position when the searchlight lamps are turned off. The feature also works with the XRCiZ™ function to return the searchlight to its Self-Park position.

SECTION 6 - POINT PAD™ OPERATION

- Press the ON/OFF button to turn the lights ON or OFF.
- Press the SPEED button to toggle between High and Low rotation speeds.
- Press the Right or Left arrows to rotate the searchlight in that direction.
- Press the Up or Down arrows to raise or lower the searchlight beam.
- To activate the XRCiZ™ feature, press and hold the ON/OFF button for more than 5 seconds. The green LED indicates that the XRCiZ™ feature is enabled.
- To deactivate the XRCiZ™ feature, press and hold the ON/OFF button for more than 5 seconds. The red LED indicates that the XRCiZ™ feature is disabled.
- An LED blinking red/green indicates that the XRCiZ™ feature is now "exercising" the searchlight.
- To activate the Self-Park feature, press and hold the Point Pad™ Speed button for more than 5 seconds.
- While the Self-Park feature is operating the searchlight, pressing any Point Pad™ button will stop the park command and leave the searchlight to follow any additional commands.
- To deactivate the Self-Park feature, press and hold the Point Pad™ Speed button for more than 5 seconds.
- An LED blinking red/green indicates that the searchlight is seeking its Self-Park position.
- The Self-Park and XRCiZ™ features are normally disabled when power is lost to the Master Controller and will have to be reactivated.

NOTE: Self-Park and the XRCiZ™ features are only available when paired with a Master Controller.

Figure 6

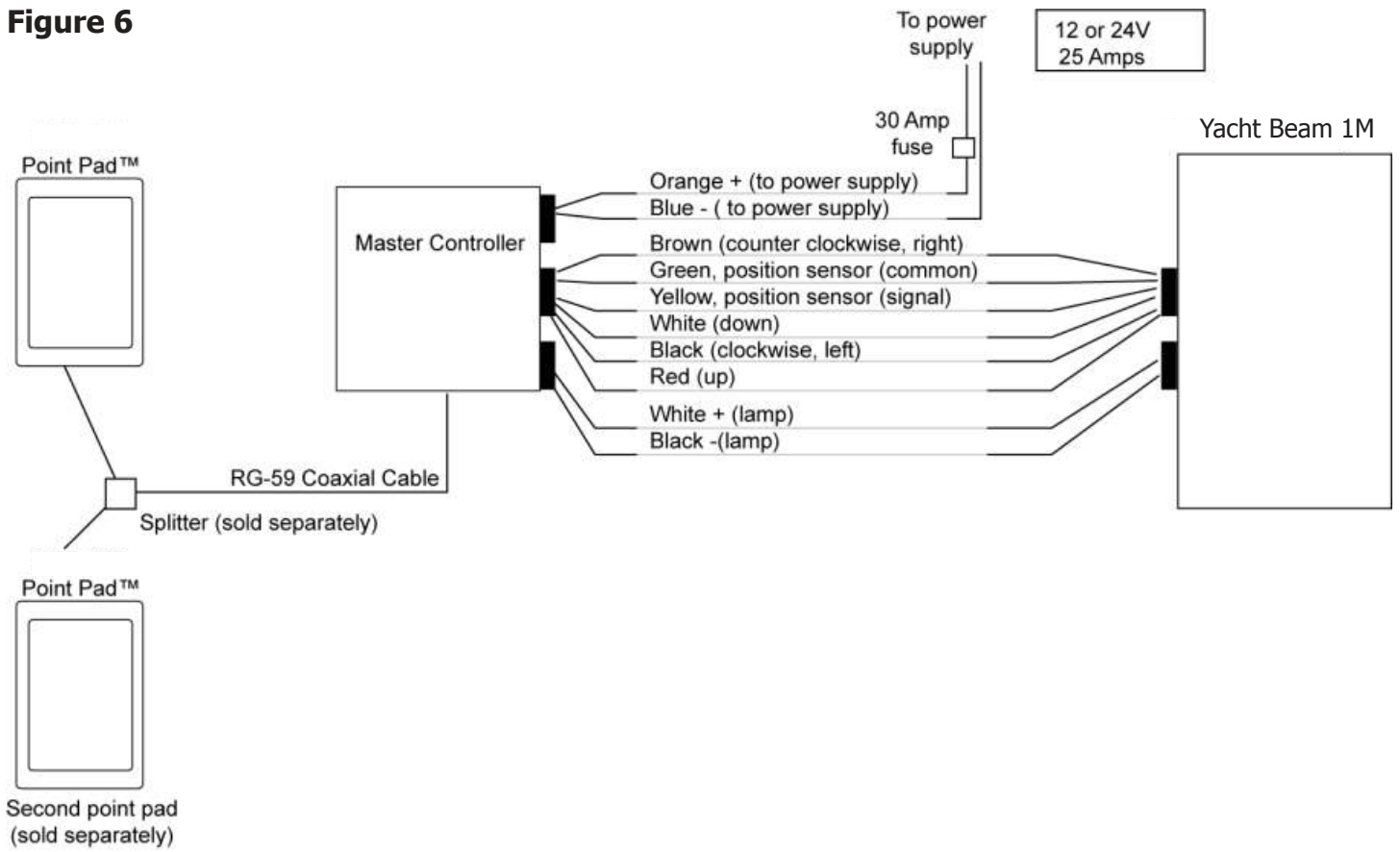

APPENDIX A - SPECIFICATIONS

CHARACTERISTICS	SPECIFICATIONS
Size	12 X 13 X 9.3 in (31 X 33 X 23.5 cm)
Weight	31 lb (14.06 kg)
Material	Cast aluminum, tempered glass
Input voltage*	12V- 24V
Amp draw	Startup 25A @ 12V, Running 8A @ 12V
Color	White
Operation	Remote controlled Point Pad™
Beam spread	6°
Elevation angle	12° up, 38° down
Rotation	360° continuous
Rotation speed	Fast 30° per second, Slow 12° per second
Elevation speed	7° per second
Lamp	- Twin 35W metal halide lamps - 1,000 hours operating life
Accessories	- Secondary Point Pad for remote control with Install Kit (ACR P/N 9282.3) - Replacement 35W halide lamp (ACR P/N 6009)
Footprint diameter	9 in (23 cm)
Limited warranty	1 year
Carton dimensions	20.5 X 14.25 X 19.25 in (52.07 X 36.20 X 48.90 cm)
Carton weight	40 lb (18.14 kg)



***CAUTION:** HID light systems, when first turned on, have a high inrush current requirement of 25 amps. If you activate the light and the lamps flicker on and off repeatedly, check the voltage being supplied. This condition can be experienced with voltage input of less than 11.5V.

APPENDIX B - KIT COMPONENTS

Product No. 1933 - Yacht Beam 1M 12-24V Searchlight Installation Kit includes:

DESCRIPTION	QUANTITY	PART #
Searchlight, Yacht Beam 1M	1	1 A3-06-2558
Point Pad™ with surface mount case	1	A3-06-2230
Master Controller unit	1	A3-06-2231-1
Case, flush mount	1	A1-18-1875-2
Gasket, surface mount	1	A1-25-0140-1
Gasket, flush mount	1	A1-25-0140-2
U Clamp	2	A1-17-1366
Nuts, nylon- lock	2	A1-05-0776
Washers	2	A1-05-0777
Cable, coaxial	30ft	A2-07-0002-6
Connector, "F"	2	A1-03-0220
Flanged 8 steel 12-10 AWG	2	A1-05-0861-8
Flanged 8 steel 12-10 AWG	8	A1-05-0861-5

APPENDIX C - WIRING DIAGRAM

YACHT BEAM 1M

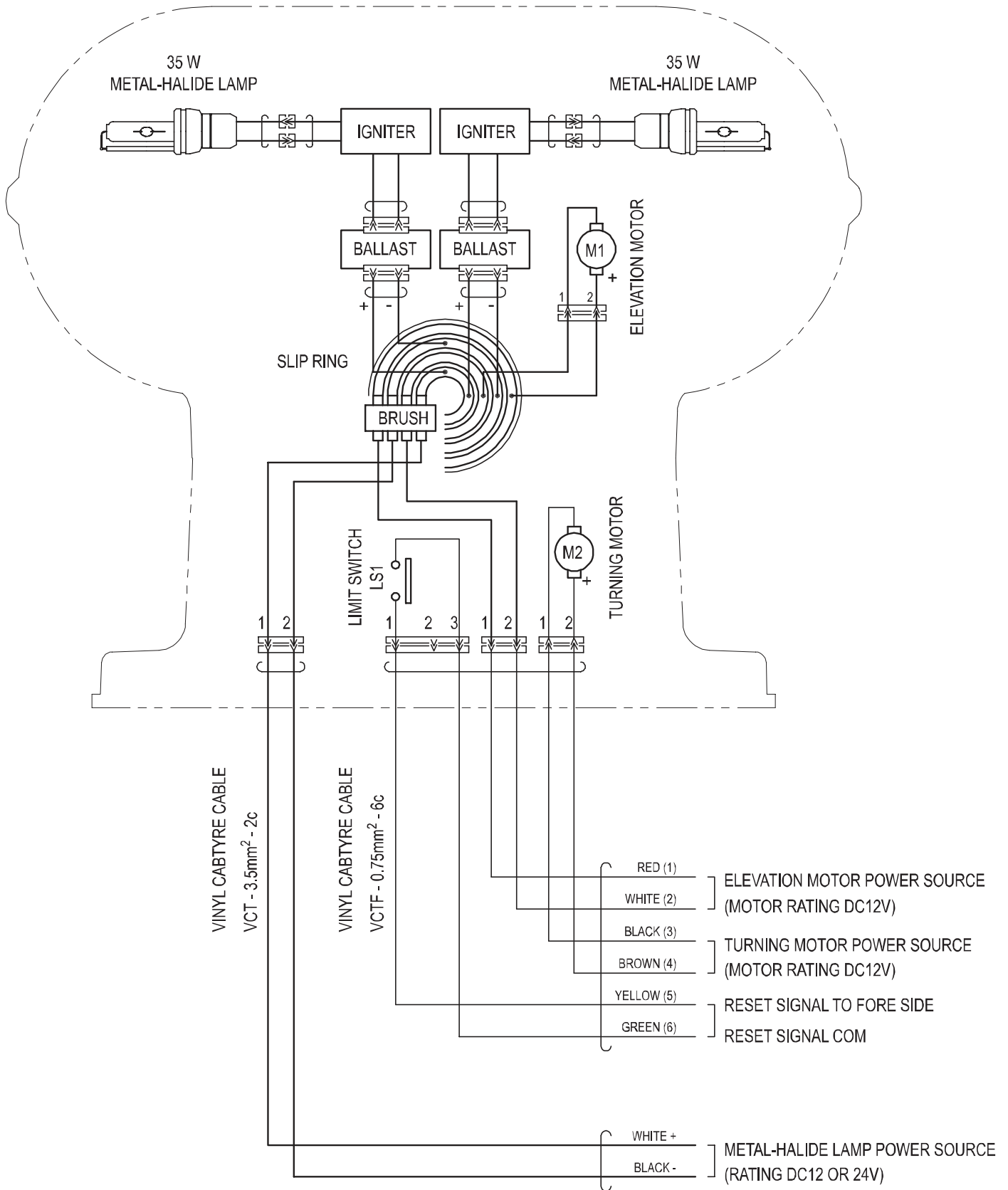

APPENDIX D - WARRANTY, NOTICES

WARRANTY LENGTH: 1 YEAR

This product is warranted against factory defect in material and workmanship for a period of 1 (one)* year from date of purchase or receipt as a gift. During the warranty period Yacht Beam will have repaired, or at its option, replaced at no cost to you for labor, materials or return transportation.

For further assistance, please contact our Technical Service Department at:

The Yacht Group

4545 Ponce de Leon Blvd.
Coral Gables, FL 33146

Questions about this warranty should be sent to us through our contact form or via Email: service@yachtbeam.com
Fax: +1 (305) 663-5551, Telephone: +1 (305) 667-5811.

This warranty does not apply if the product has been damaged by accident or misuse, or as a result of service or modification by other than the manufacturer. The COMPANY MAKES NO REPRESENTATION OR WARRANTY OF ANY KIND, EXPRESS OR IMPLIED, AS TO MERCHANTABILITY OR FITNESS FOR A PARTICULAR PURPOSE, OR ANY OTHER MATTER WITH RESPECT TO THIS PRODUCT, except as otherwise expressly stated in the previous paragraph.

The Company shall not be liable for consequential or special damages. In order to place the warranty in effect, choose a form above and complete it entirely. Or you may fill out the registration card accompanying your product (if applicable) which must be returned to the Yacht Group within ten days of purchase.

For information on product returns, please review our Returns Policy at www.YachtBeam.com

Notices

The Yacht Group diligently works to provide a high quality Product Support Manual, however, despite best efforts, information is subject to change without notice, and omissions and inaccuracies are possible. The Yacht Group cannot accept liability for manual contents. To ensure that you have the most recent version of the Product Support Manual, please visit the Yacht Beam website at www.YachtBeam.com